

3200ET TIMER

Service Manual

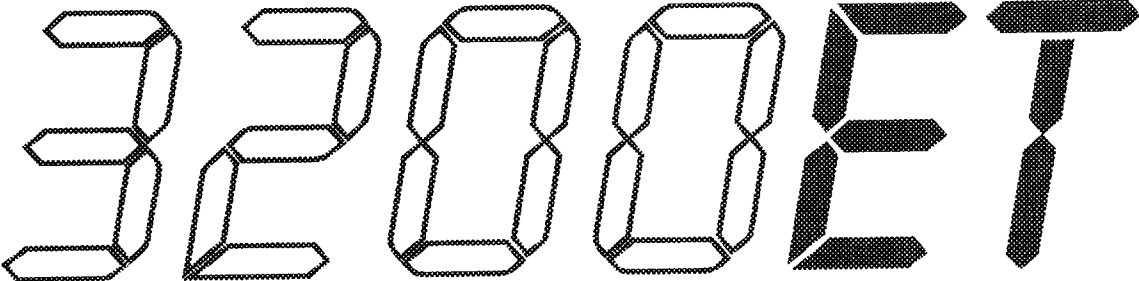

IMPORTANT: Fill in pertinent information on page 2 for future reference.

3200ET Timer

Installation And Start-Up Procedures

Timer Programming

Water Hardness _____

System Capacity _____

Regeneration Time _____

Regeneration Cycle Step Programming

Step #1 _____

Step #2 _____

Step #3 _____

Step #4 _____

Step #5 _____

Notes:

1. Place the conditioner tank where you want to install the unit, making sure the tank is level and on a firm base.
2. During cold weather it is recommended that the installer warm the valve up to room temperature before operating.
3. All plumbing should be done in accordance with local plumbing codes. The pipe size for the drain, distributor size/length, and Backwash flow rate should be set per specifications found in the valve service manual.
4. Lubricate the distributor O-ring seal and tank O-ring seal. Place the main control valve on tank. Note: Only use silicone lubricant.
5. Solder joints near the drain must be done prior to connecting the Drain Line Flow Control fitting (DLFC). Leave at least 6" between the DLFC and solder joints when soldering pipes that are connected on the DLFC. Failure to do this could cause interior damage to DLFC.
6. Teflon tape is the only sealant to be used on the drain fitting.
7. Make sure that the floor is clean beneath the salt storage tank and that it is level.
8. Place approximately 1" of water above the grid plate. If a grid is not utilized, fill to the top of the air check in the salt tank. Do not add salt to the brine tank at this time.
9. On units with a by-pass, place in by-pass position. Turn on the main water supply. Open a cold soft water tap nearby and let run a few minutes or until the system is free from foreign material (usually solder) that may have resulted from the installation. Once clean, close the water tap.
10. Place the by-pass in service position and let water flow into the mineral tank. When water flow stops, slowly open a cold water tap nearby and let run until the air is purged from the unit. Then close tap.
11. Plug the valve into an approved power source. Once the valve is powered it will drive to the Service Position.

3200ET Timer

Installation And Start-Up Procedures (Cont'd.)

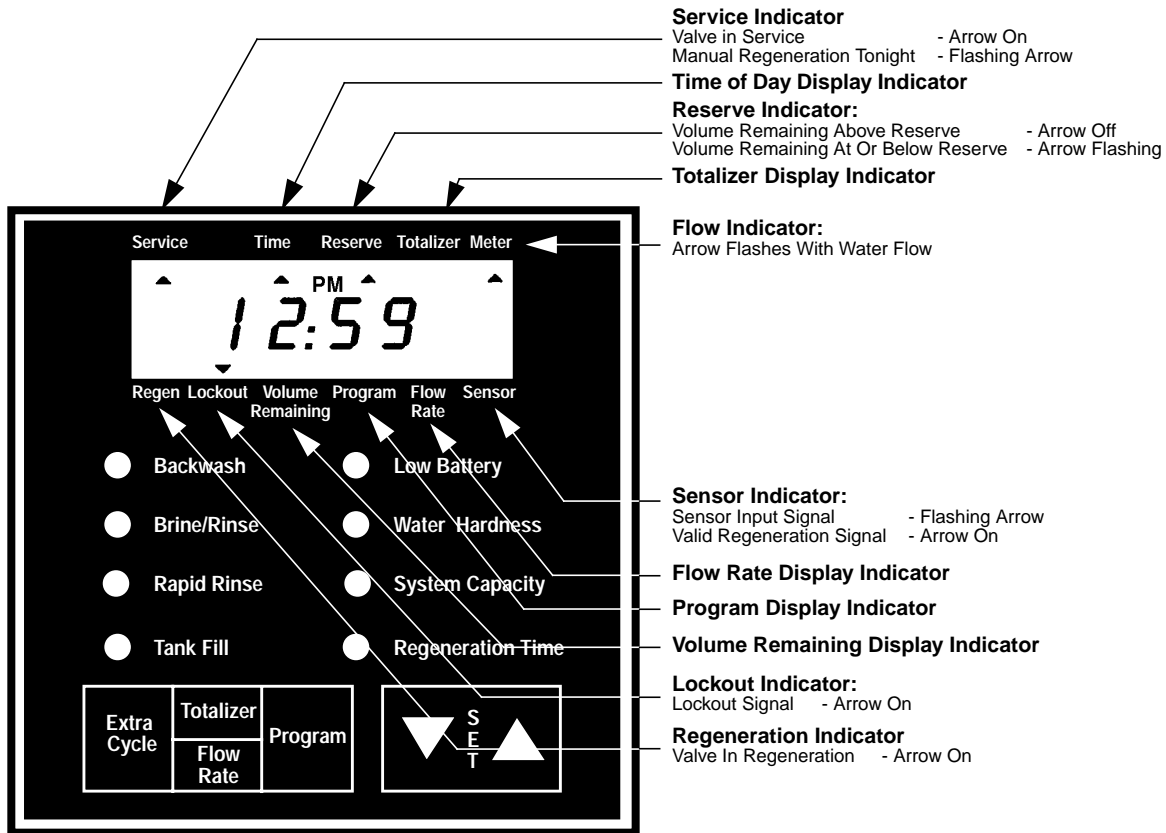

12. Once the valve has reached Service normal operation is resumed. In Normal Operation the Time Of Day and, if flow meter equipped, the Volume Remaining Displays will alternate being viewed. Set the Time Of Day Display by depressing the Up or Down Set Button to the correct time. (See Fig. 1)

For Example:
12:59 P.M.
(Valve in Service)



13. *Flow Meter Equipped Valves Only:* The Volume Remaining Display is the volume of water (in gallons) remaining prior to regeneration, including any reserve capacity. Without any water usage the Meter Arrow should be either off or on but not changing. Open a soft water tap. The Meter Arrow should begin flashing at a rate that varies with flow rate. Close the tap after 3 - 5 gallons of water flow.

For Example:
25 Gallons Of Water Remaining
(Valve in Service)
(No water flow)
(Volume is below reserve capacity, Reserve arrow flashing)

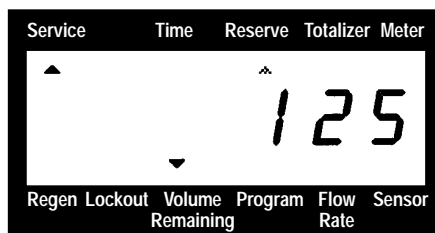

For Example:
0 Gallons Of Water Remaining
(Valve in Service)
(Water flowing)
(Volume is below reserve capacity, Reserve arrow flashing)

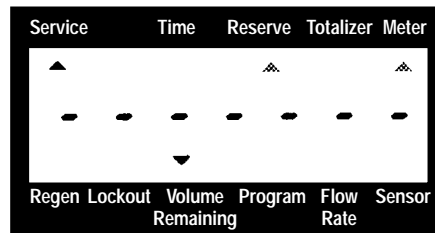

3200ET Timer

Installation And Start-Up Procedures (Cont'd.)

14. Manually initiate a regeneration cycle and allow water to run to drain for 3 to 4 minutes. Next, manually step the valve through a regeneration cycle checking valve operation in each step.

A. Initiating Regeneration (Depending on the timer regeneration type you have one or two (2) Options):

1. **Press and Release the Extra Cycle Button.** With Immediate Regeneration Timers the control will go into Regeneration immediately. With Delayed Regeneration Timers the Service Arrow will begin to flash immediately and a regeneration will occur at the preset regeneration time (i.e. 2:00 a.m.)
2. **Press and Hold for 5 seconds the Extra Cycle Button.** The control will go into Regeneration immediately.

B. Control Operation

1. During Regeneration: During Regeneration the control will display which regeneration step number the valve is advancing to, or has reached, and the time remaining in that step.

For Example:

(Valve is advancing to Regeneration Step #1)
(#1 flashing)
(Regeneration arrow on)

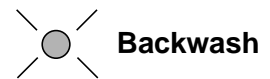
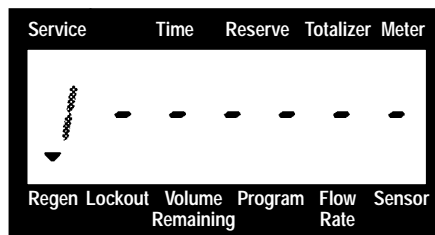

2. When the first cycle step is reached, a red LED will turn on to indicate the current regeneration cycle step.

For Example:

(Regeneration Step #1 has been reached)
(10.0 minutes remain in Step #1)
(Regeneration arrow on)

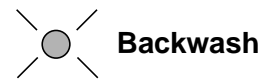
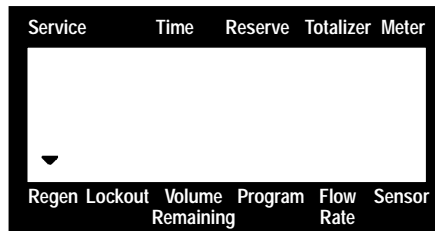

3. Pushing the Extra Cycle Button during a regeneration step will immediately advance the valve to the next regeneration step position.
4. Pushing the Up or Down Set Button during a regeneration step will adjust the time remaining in that current regeneration step. Programmed regeneration step times **will not** be changed.
5. Once all regeneration cycle steps have been completed the valve will return to Service and resume normal operation.

15. Manually step the valve to the Brine Draw position (see Step #14) and allow the valve to draw water from the brine tank until it stops. Note: The air check will check at approximately the midpoint of the screened intake area.

16. Manually step the valve to the Brine Refill position and allow the valve to return to Service automatically.

17. Make sure the brine refill time (salt dosage) is set as recommended by the manufacturer.

18. With the valve in Service, check that there is about 1" of water above the grid in the brine tank, if used.

19. Fill the brine tank with salt.

20. A **9V Alkaline Battery** is recommended to be installed at all times for proper valve operation. The control will indicate when the battery needs to be replaced by turning on the Low Battery LED.

3200ET Timer

Control Operation

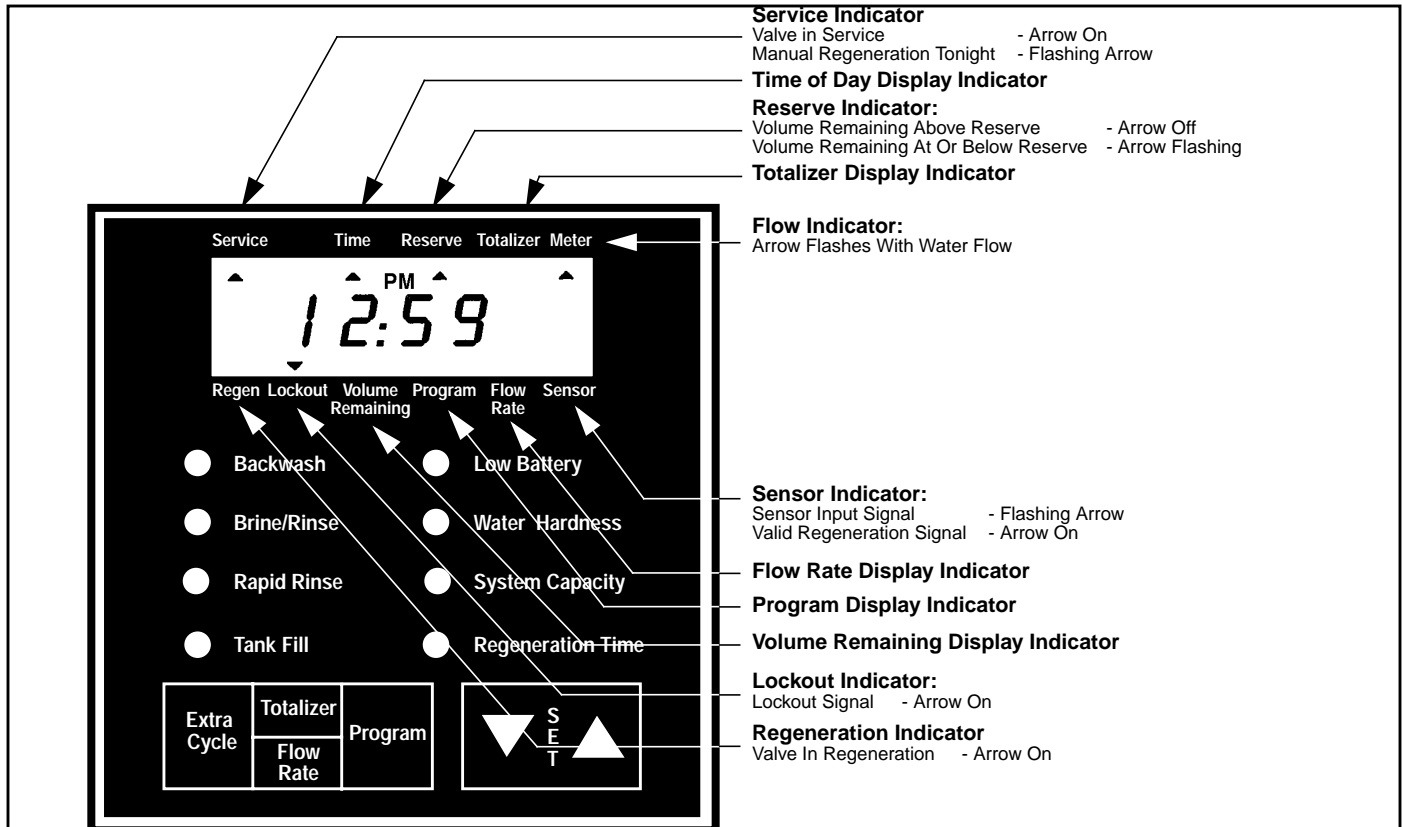

NORMAL CONTROL OPERATION

Flow Meter Equipped Delayed Regeneration Valves -

In Normal Operation the Time Of Day Display will alternate being viewed with the Volume Remaining Display. Water flow through the unit is indicated by the Meter Arrow that will flash in a direct relationship to flow rate. As treated water is used, the Volume Remaining Display will count down from a maximum value to the calculated reserve capacity. Once this occurs, the Reserve Arrow will begin to flash as a indication that reserve capacity is being used. At the preset Regeneration Time a regeneration cycle will then be initiated immediately.

For Example:

125 Gallons of Water Remaining
 (Valve in Service)
 (No water flow)
 (Volume is below reserve capacity)

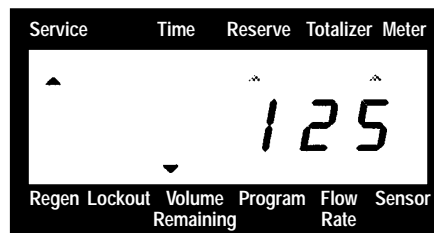

For Example:

0 Gallons of Water Remaining
 (Valve in Service)
 (Water flowing, Meter arrow flashing)
 (Volume is below reserve capacity)

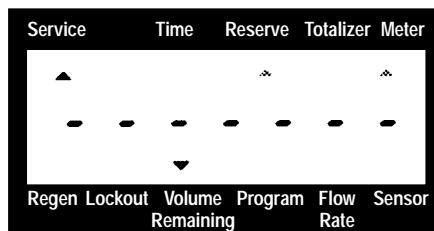

3200ET Timer

Control Operation (Cont'd.)

Timeclock Regeneration Valves -

In Normal Operation the Time Of Day Display will be viewed at all times. The control will operate normally until the days since the last regeneration reaches the preset number of days. Once this occurs, a regeneration cycle will then be initiated immediately at the preset Regeneration Time.

Flow Meter Equipped Immediate Regeneration Valves -

In Normal Operation the Time Of Day Display will alternate being viewed with the Volume Remaining Display. Water flow through the unit is indicated by the Meter Arrow that will flash in a direct relationship to flow rate. As treated water is used, the Volume Remaining Display will count down from a maximum value to zero. Once this occurs a regeneration cycle will then be initiated immediately.

For Example:

525 Gallons of Water Remaining
(Valve in Service)
(Water flowing, Meter arrow flashing)

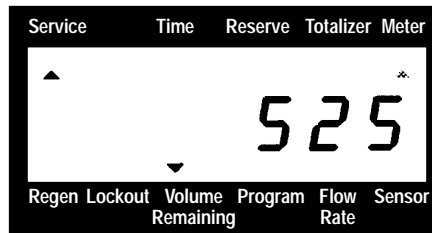

Sensor Immediate Regeneration Valves -

In Normal Operation the Time Of Day Display will be viewed at all times. The control will operate normally until a valid sensor input signal is received. Once this occurs, a regeneration cycle will then be initiated immediately. The Sensor Input Arrow will flash until the signal is determined to be valid.

Sensor Delayed Regeneration Valves -

In Normal Operation the Time Of Day Display will be viewed at all times. The control will operate normally until a valid sensor input signal is received. Once this occurs, a regeneration cycle will then be initiated immediately at the preset Regeneration Time. The Sensor Input Arrow will flash until the signal is determined to be valid. Then the Reserve Arrow will begin to flash as a indication that reserve capacity is being used.

For Example:

12:58 A.M. With Invalid Sensor Signal
(Valve in Service)
(Sensor arrow flashing)



For Example:

12:59 A.M. With Valid Sensor Signal
(Valve in Service)
(Sensor arrow on)
(Reserve arrow flashing) (Delayed Regen.)

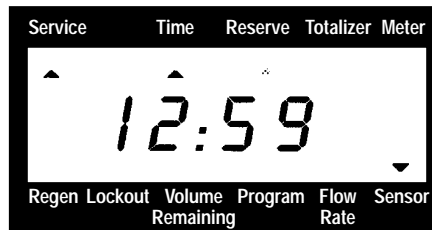

Immediate Regeneration Valves With Days Between Regeneration Override Set -

When the valve has reached its set Days Since Regeneration Override value a regeneration cycle will be initiated immediately. This event occurs regardless of the Volume Remaining display having reached zero.

Delayed Regeneration Valves With Days Between Regeneration Override Set -

When the valve has reached its set Days Since Regeneration Override value a regeneration cycle will be initiated at the preset Regeneration Time. This event occurs regardless of the Volume Remaining display having reached the calculated reserve capacity.

3200ET Timer

Control Operation (Cont'd.)

CONTROL OPERATION DURING A POWER FAILURE

During a power failure all control displays will be turned off and regeneration cycles delayed. The control will otherwise continue to operate normally until line power is restored or battery backup power is lost.

1. If battery backup power is never lost during a power outage, the control will continue to operate normally, without the loss of data, until line power is restored.
2. If battery backup power is lost during a power outage, the control will store the current Time Of Day, Volume Remaining, Regeneration Cycle Status, and various diagnostic displays. These stored displays will then be used upon line power restoration until updated ones are created. To indicate this type of failure, the control will flash the current Time Of Day Display to indicate that this display and the Volume Remaining Display may not be correct.

CONTROL OPERATION DURING REGENERATION

In regeneration the control will display what regeneration step number the valve is advancing to, or has reached, and the time remaining in that step. Once all regeneration cycle steps have been completed the valve will return to service and resume normal operation.

1. First the Regeneration Arrow turns on. Then the display below is viewed to indicate that the valve is advancing to the first regeneration cycle step.

For Example:

(Valve is advancing to Regeneration Step #1)
(#1 Flashing)

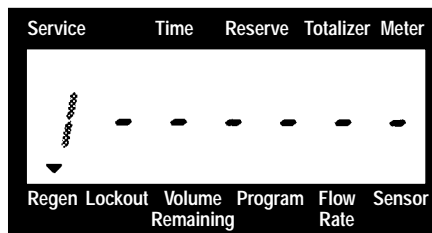

2. When the first cycle step is reached, the display becomes as shown below. As time passes the control will begin to decrement the step time in tenths of minutes until zero is reached. A red LED will also turn on to indicate the current regeneration cycle step.

For Example:

(Regeneration Step #1 has been reached)
(10.0 minutes remain in Step #1)

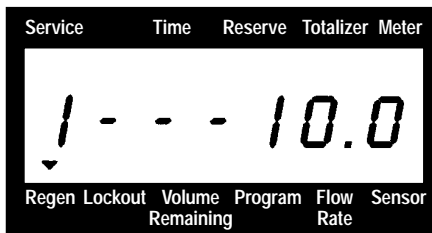

3. Once the step time reaches zero, the valve drive motor will turn on and the Regeneration Time Remaining Display revert to all dashes until the next regeneration cycle step position is reached. Steps #2 and #3 will then be repeated until all regeneration cycle steps have been completed and the valve has returned to Service.
4. Pushing the Extra Cycle Button during a regeneration cycle will immediately advance the valve to the next cycle step position and resume normal step timing.
5. Pushing the Up or Down Set Button during a regeneration cycle will adjust the time remaining in a regeneration cycle step. Actual regeneration cycle step programming will not be changed.

3200ET Timer

Control Operation (Cont'd.)

CONTROL OPERATION DURING PROGRAMMING

The control will only enter the Program Mode with the valve in Service and operating on line power. While in the Program Mode the control will continue to operate normally monitoring water usage and keeping all displays up to date. Control programming is stored in memory permanently with or without line or battery backup power.

LOCKOUT INPUT OPERATION

The Lockout Arrow will turn on whenever a Lockout Signal is being received by the control. Any requests for regeneration will be delayed until this signal is removed. Regeneration will then proceed normally.

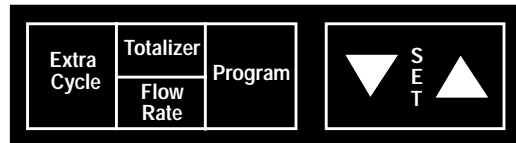

Keypad Operation

Extra Cycle Button

Pushing this button will initiate a regeneration cycle independently of actual valve conditions.

1. With immediate regeneration valves this extra regeneration will occur immediately.
2. With delayed regeneration valves this extra regeneration will occur at the set Regeneration Time. A regeneration cycle can be forced to occur immediately by pushing and holding in for 5 seconds this button.

Totalizer/Flow Rate Button

This button is used to view the Totalizer and Flow Rate Displays. Depressing the button once will display flow rate. Depressing the button again will display the total accumulation of water flow through the valve since it was last reset. Depressing the button once more will return the display to Time Of Day or Volume Remaining. The Totalizer display is reset by depressing and holding for 25 seconds this button. During the 25 seconds, the Totalizer Arrow will flash as an indicator to the operator that the display is being reset properly.

Program Button

This button is used by the installer to program those settings indicated on the front panel by red LEDs.

Up Set Button

This button is used to set the current time of day, adjust time remaining in a regeneration cycle step and in valve programming. The Up Arrow Button will increment a display setting.

Down Set Button

This button is used to set the current time of day, adjust time remaining in a regeneration cycle step and in valve programming. The Down Arrow Button will decrement a display setting.

Low Battery Indicator



When the control is operating on line power, this red LED will turn on whenever the **9V Alkaline Battery** (Not Included) used for memory backup needs to be replaced. The battery is stored against the valve backplate. In the event of a power outage the battery will maintain current operating displays for approx. 24 hours at maximum battery capacity.

Notes

3200ET Timer

3200ET Timer Assemblies

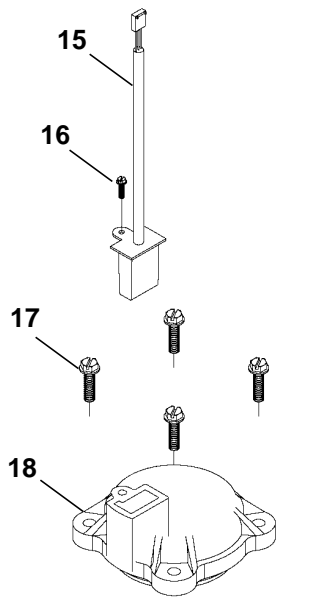

**Standard 3/4" To 2.0"
Electronic Flow Meter
Cap Assy.**

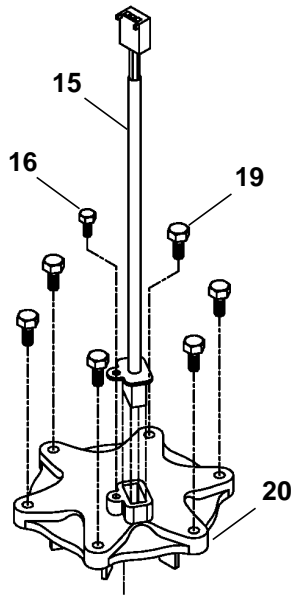

**Standard 3.0"
Electronic Flow Meter
Cap Assy.**

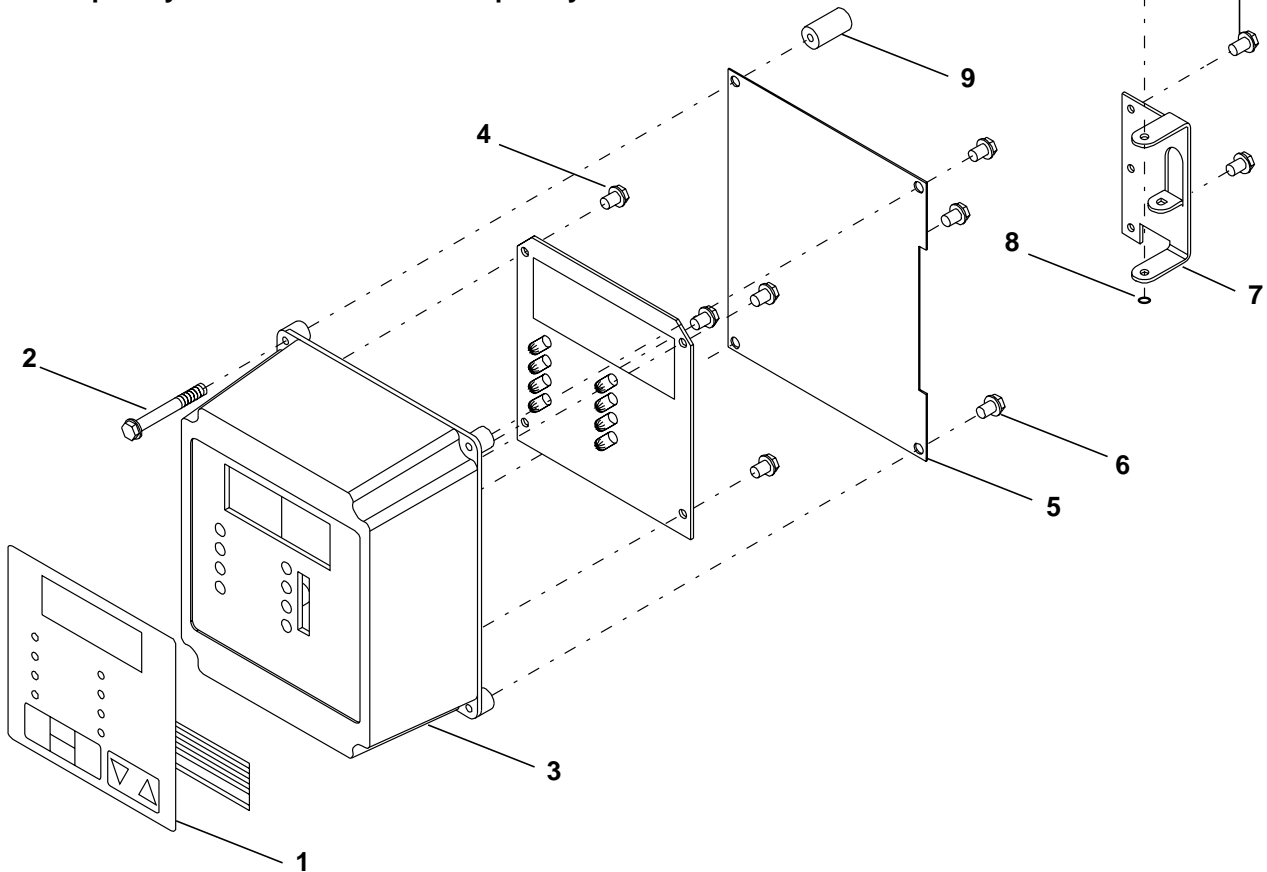
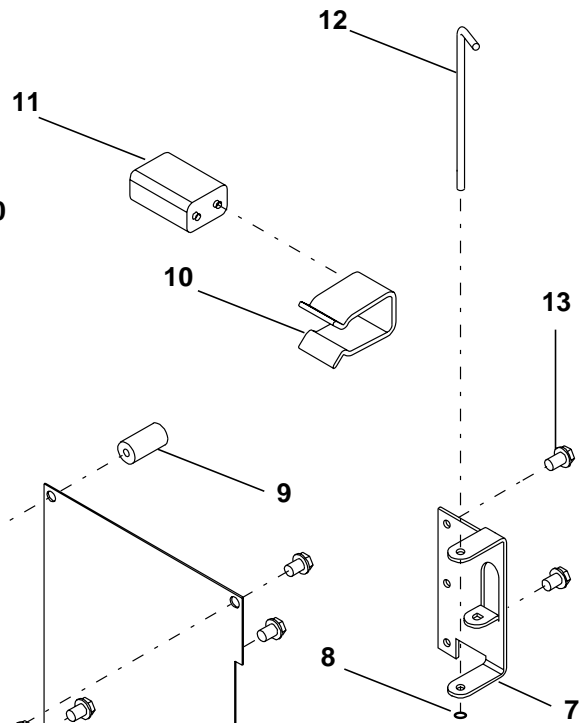

3200ET Timer

3200ET Timer Assemblies Parts List

Item No.	Quantity	Part No.	Description
1	1	19144-02	Assembly, Switch Pad - Standard Downflow
		19144-06	Assembly, Switch Pad - Upflow Variable Brining
		19144-05	Assembly, Switch Pad - Upflow Brine First
		19144-04	Assembly, Switch Pad - Standard Upflow
2	1	18735	Screw, Hex Wash. #8 x 1 1/2
3	1	18741	Housing, Circuit Board - No Hinge
	1	18741-01	Housing, Circuit Board - Right Hinge
	1	18741-02	Housing, Circuit Board - Left Hinge
4	1	27178-11	24V 3200ET Circuit Board (Version 2.0 Software)
		27178-13	120V 3200ET Circuit Board (Version 2.0 Software)
		27178-14	240V 3200ET Circuit Board (Version 2.0 Software)
5	1	18764	Shield, Circuit Board
6	3	12758	Screw, Hex Washer #10 x 5/8
7	1	18749	Bracket, Hinge (Not Used With 18741)
8	1	15159	O-Ring .005
9	1	18814	Spacer, Elect. Housing (Not Used With 18741)
10	1	17831-01	Battery Clip
11	1		9V Alkaline Battery (Not Included)
12	1	14723	Pin, Timer Hinge
13	2	10300	Screw, Hex Washer #8 x 3/8
		40041-03	Harness Low Voltage 2750 with 3200ET 2510, 2750, 2850, 2900
		40041-04	Harness Low Voltage 3150 w/3200ET, 3150/3900
		40041-06	Harness Low Voltage 9000 w/3200ET, 9000/9500
		40043-01	Harness Power 2750/2900 w/3200ET, 2510/2750/2850/2900
		40043-02	Harness Power 3150/3900 w/3200ET
		40043-03	Harness Power 9000/9500 w/3200ET
		19891	Harness, Battery, All Valves
14	4	17020	Screw, Slot Ind Hex, 6-20 x 3/8

Optional Electronic Flow Meter Cap Parts List

Item No.	Quantity	Part No.	Description
15	1	19121-02	Assy. Mtr. Cable 1.8 ft. 2500/9000/9500 System 4
		19121-03	Assy. Mtr. Cable 8 ft. All Valves Systems 6, 7
		19121-04	Assy. Mtr. Cable 25 ft. All Valves All Systems (Optional)
		19121-05	Assy. Mtr. Cable 2.3 ft. 2750/2850/2900/3150/3900 Systems 4, 5, 9
16	1	17798	Screw, Hex Washer
17	4	12473	Screw, Hex Washer #10-24 x 5/8
18	1	14716	Meter Cap Assy., Electronic
19	6	12112	Screw, Hex Head
20	1	14716-01	Meter Cap Assy., 3.0" Electronic

3200ET Timer

3200ET System #4 - 1500/2500/2750/2850/3130/3150

LOCKOUT AND SENSOR INPUT SIGNALS ARE GENERATED BY SHORTING
TERMINAL BLOCK POSITIONS #7 AND #8 OR #12 AND #13.

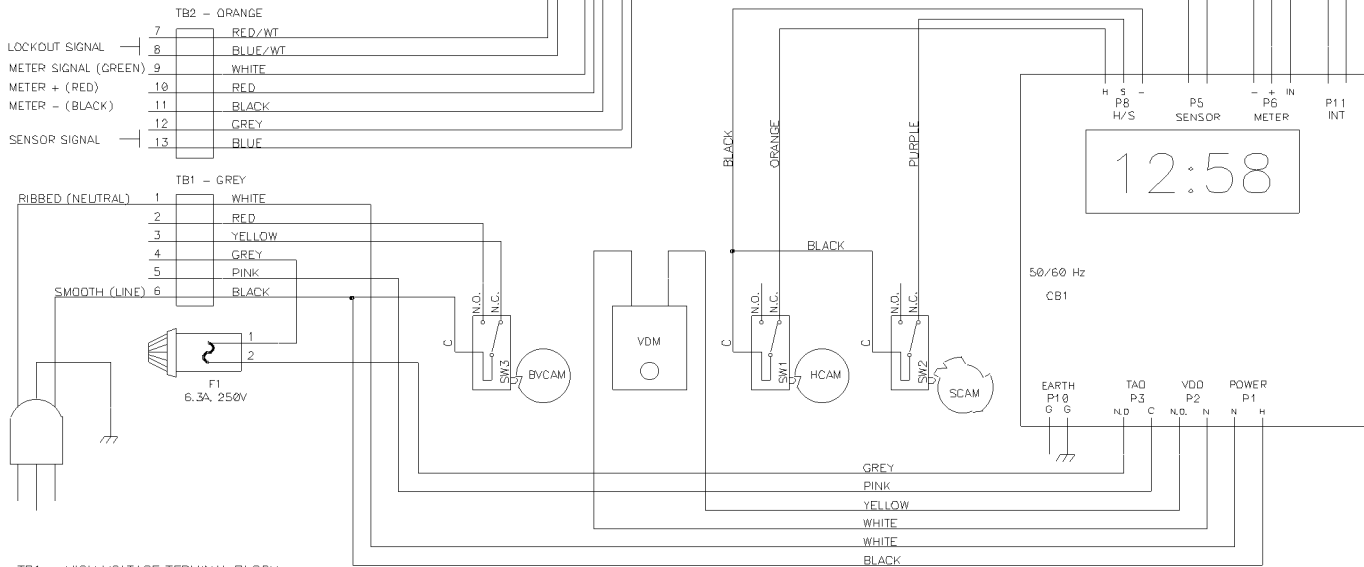

- TB1 - HIGH VOLTAGE TERMINAL BLOCK
- TB2 - LOW VOLTAGE TERMINAL BLOCK
- CB1 - 3200ET CIRCUIT BOARD
- F1 - TIMED AUXILIARY OUTPUT FUSE
- VDM - VALVE DRIVE MOTOR
- SW1 - HOMING SWITCH
- SW2 - STEP SWITCH
- SW3 - BRINE CAM SWITCH
- HCAM - VALVE HOMING CAM
- SCAM - VALVE STEP CAM
- BVCAM - BRINE VALVE CAM

System #4 - Single Unit Meter/Timeclock/Sensor Regeneration

3200ET Timer

3200ET - 9000/9500

LOCKOUT AND SENSOR INPUT SIGNALS ARE GENERATED BY SHORTING
TERMINAL BLOCK POSITIONS #7 AND #8 OR #12 AND #13.

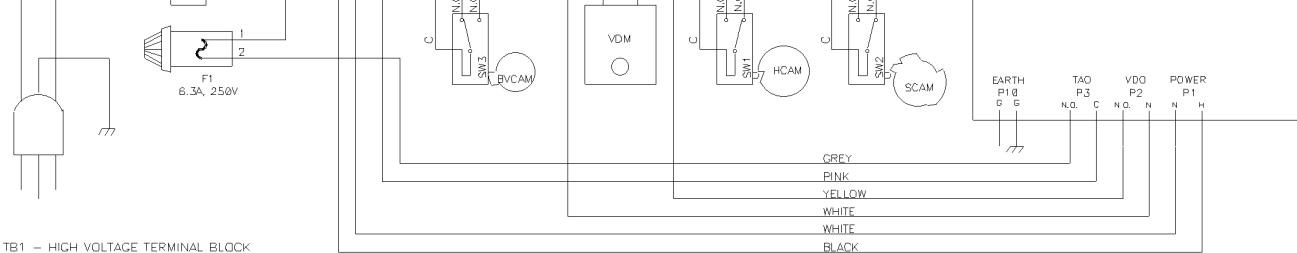
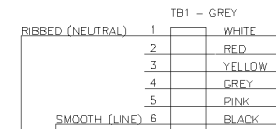
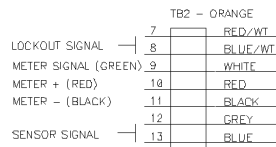

- TB1 - HIGH VOLTAGE TERMINAL BLOCK
- TB2 - LOW VOLTAGE TERMINAL BLOCK
- CB1 - 3200ET CIRCUIT BOARD
- F1 - TIMED AUXILIARY OUTPUT FUSE
- VDM - VALVE DRIVE MOTOR
- SW1 - HOMING SWITCH
- SW2 - STEP SWITCH
- SW3 - BRINE CAM SWITCH
- HCAM - VALVE HOMING CAM
- SCAM - VALVE STEP CAM
- BVCAM - BRINE VALVE CAM

Twin Unit Meter/Timeclock/Sensor Regeneration

3200ET Timer

3200ET System #4 - 2900/2930/3900

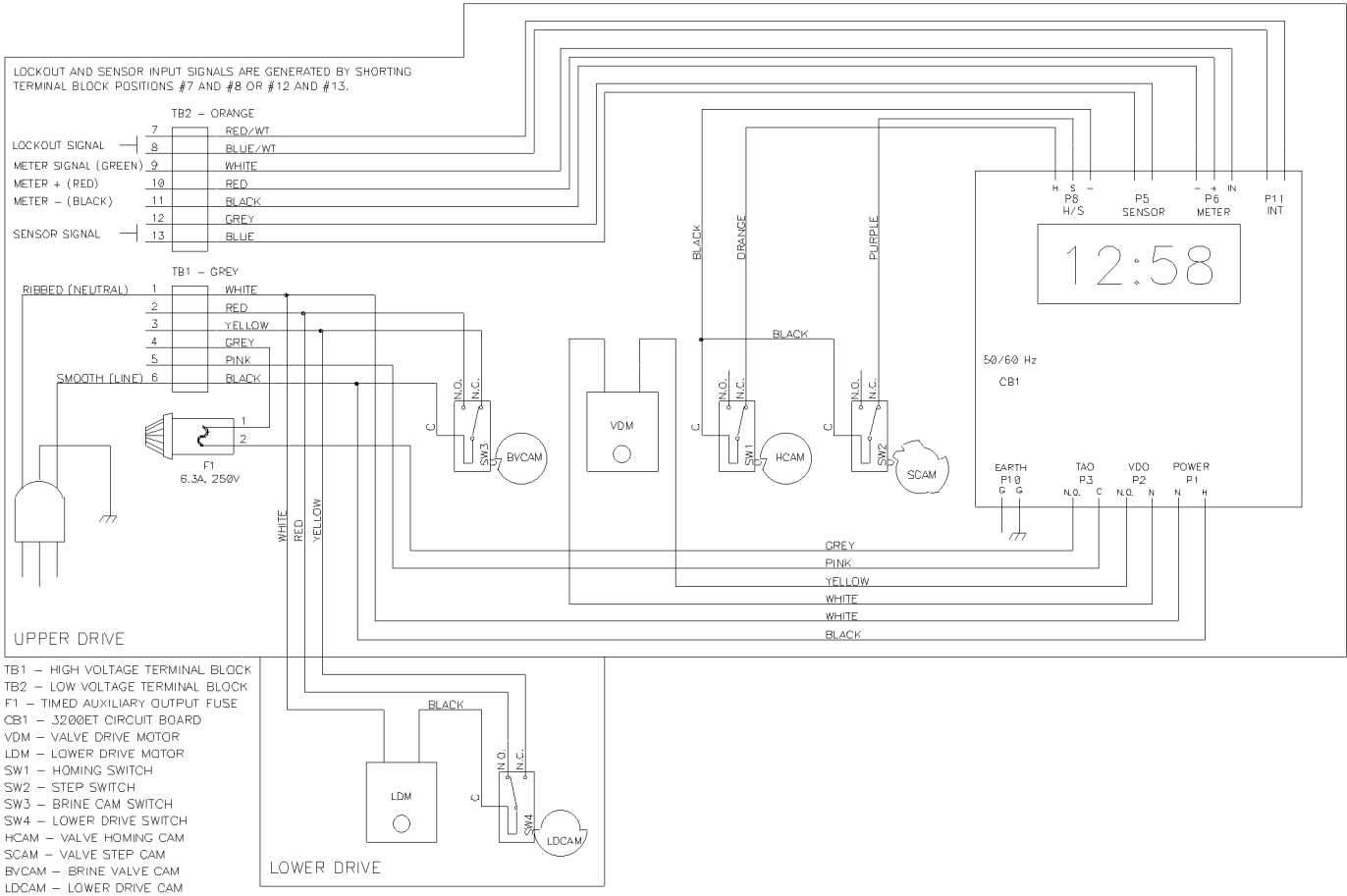

System #4 - Single Unit Meter/Timeclock/Sensor Regeneration

3200ET Timer

3200ET Systems #5 And #6 - 2750/2850/3130/3150

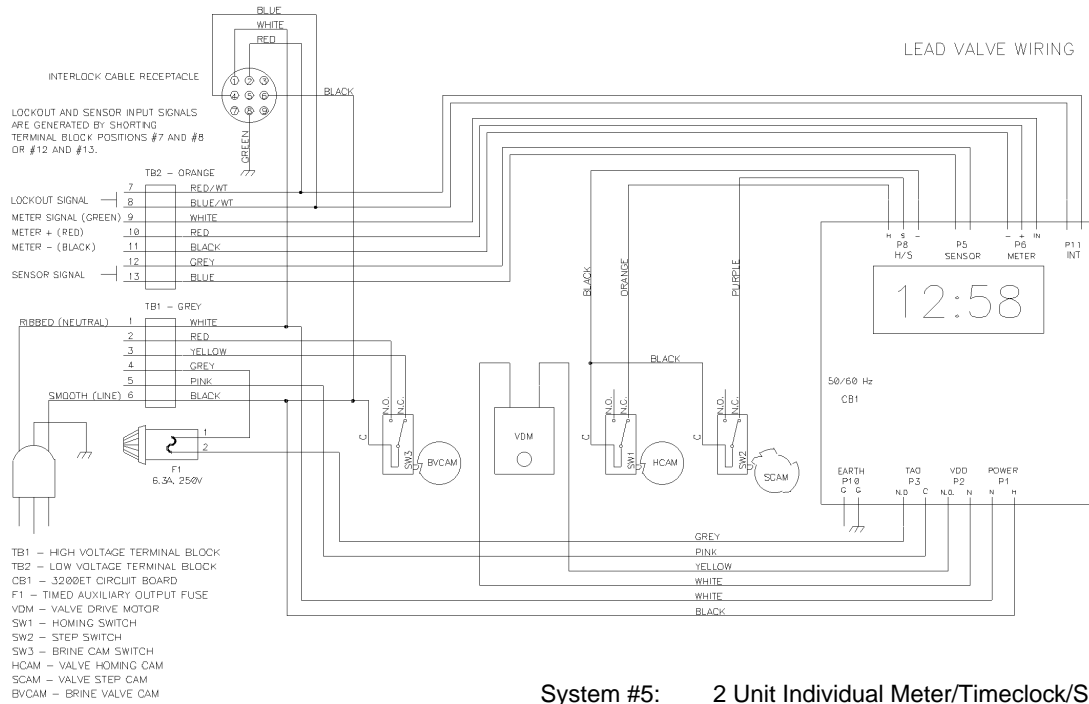

- System #5: 2 Unit Individual Meter/Timeclock/Sensor Interlocked Regeneration. Both Units in Service.
- System #6: 2 Unit Single Meter/Timeclock/Sensor Series Regeneration. Both Units in Service.

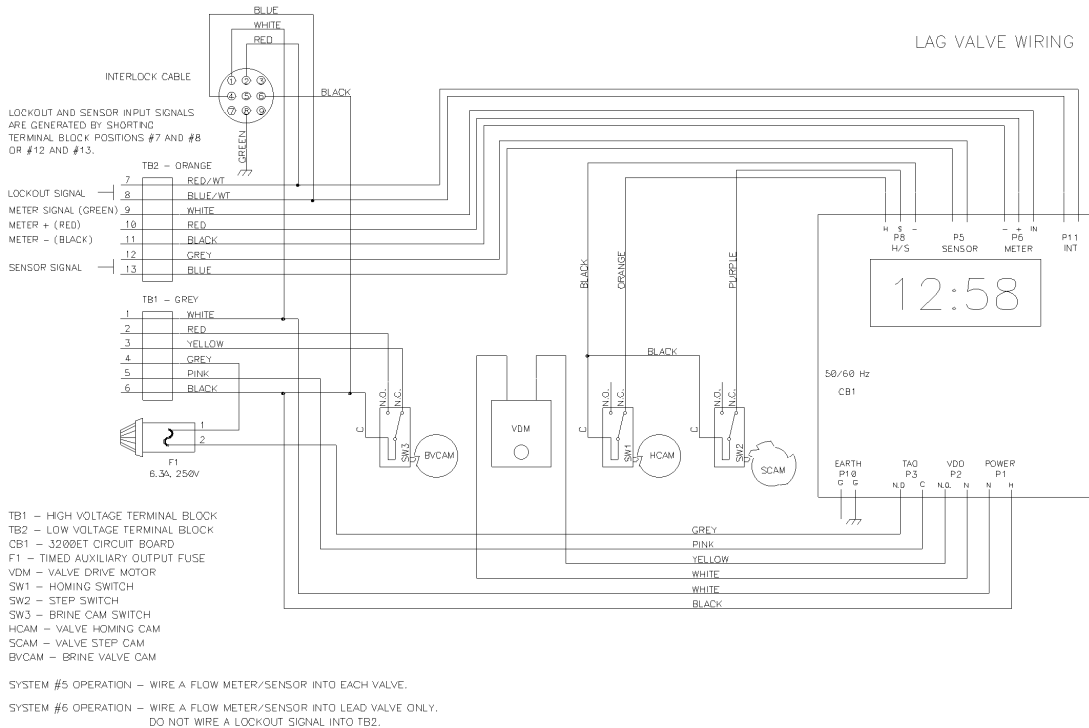

3200ET Timer

3200ET System #5 And #6 - 2900/2930/3900

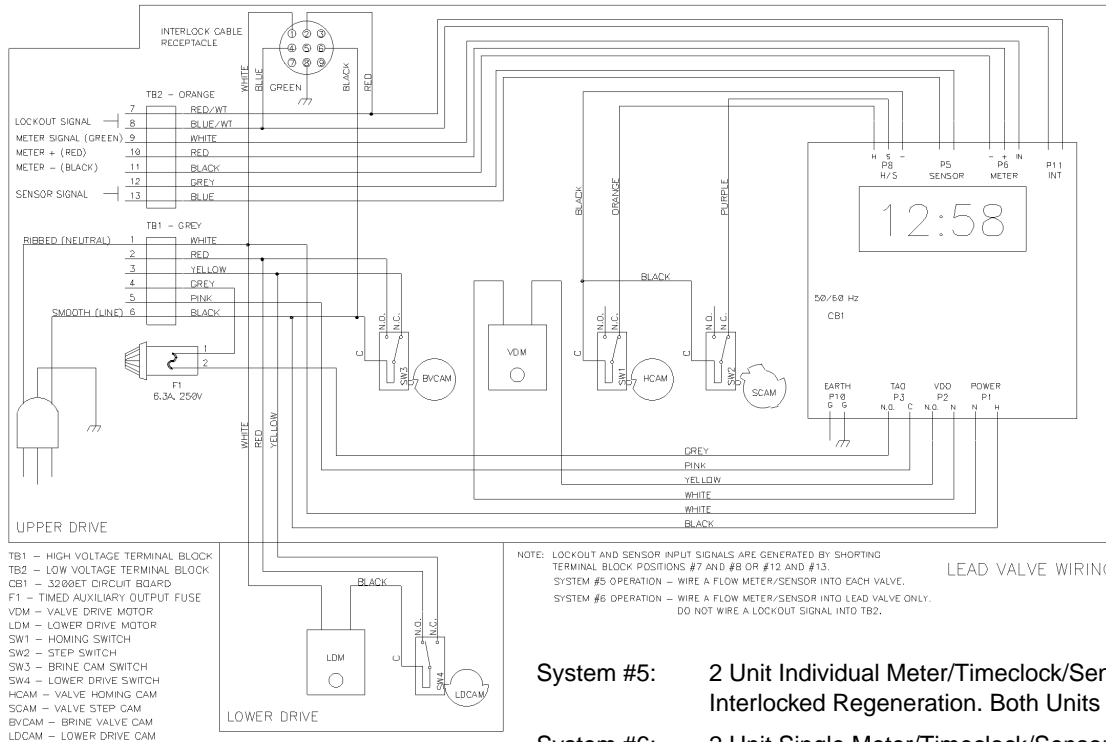

- System #5:** 2 Unit Individual Meter/Timeclock/Sensor Interlocked Regeneration. Both Units in Service.
- System #6:** 2 Unit Single Meter/Timeclock/Sensor Series Regeneration. Both Units in Service.

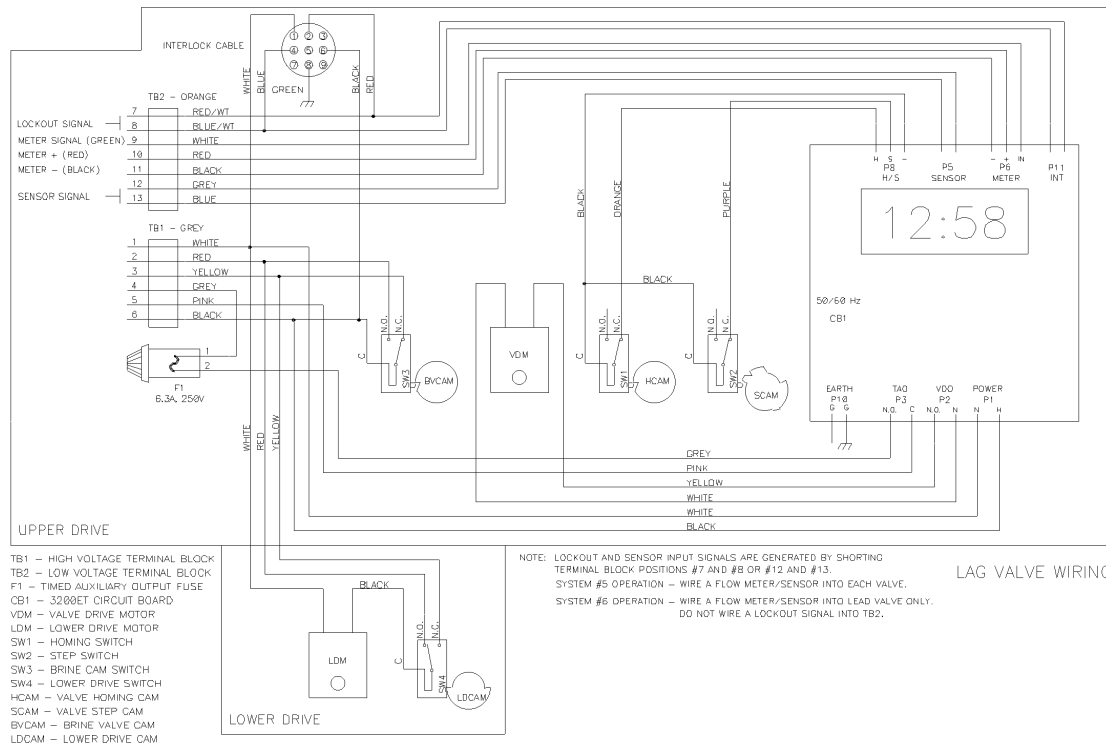

3200 Timer

3200ET Systems #7/#8 (3-Way Solenoid Output) - 2750/2850/3130/3150

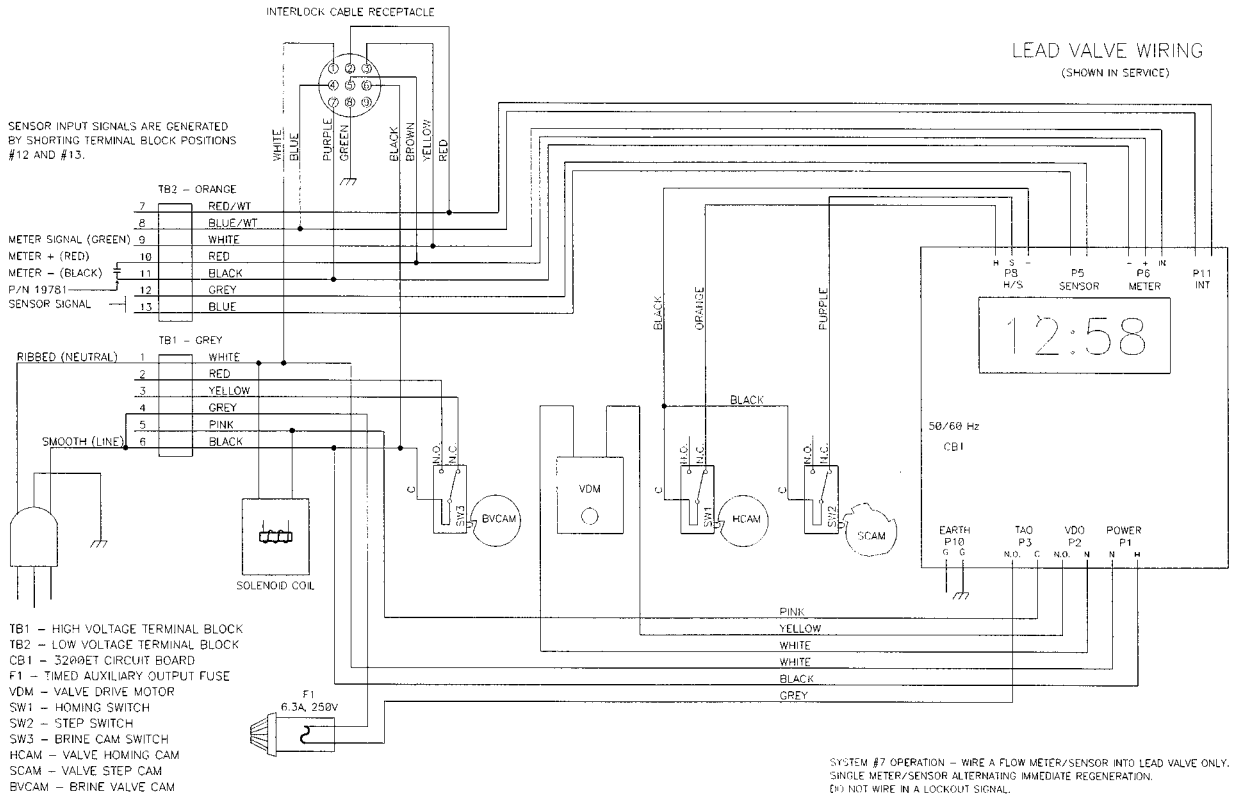

SOLENOID OUTPUT TO BE SET TO TURN ON AT THE START OF BACKWASH AND TURN OFF WHEN RETURNED TO SERVICE.

SYSTEM #7 OPERATION - WIRE A FLOW METER/SENSOR INTO LEAD VALVE ONLY. SINGLE METER/SENSOR ALTERNATING IMMEDIATE REGENERATION. (N) NOT WIRE IN A LOCKOUT SIGNAL.

SYSTEM #8 OPERATION - WIRE A FLOW METER/SENSOR INTO LEAD VALVE ONLY. SINGLE METER/SENSOR ALTERNATING DELAYED REGENERATION WITH IMMEDIATE SERVICE TRANSFER. DO NOT WIRE IN A LOCKOUT SIGNAL.

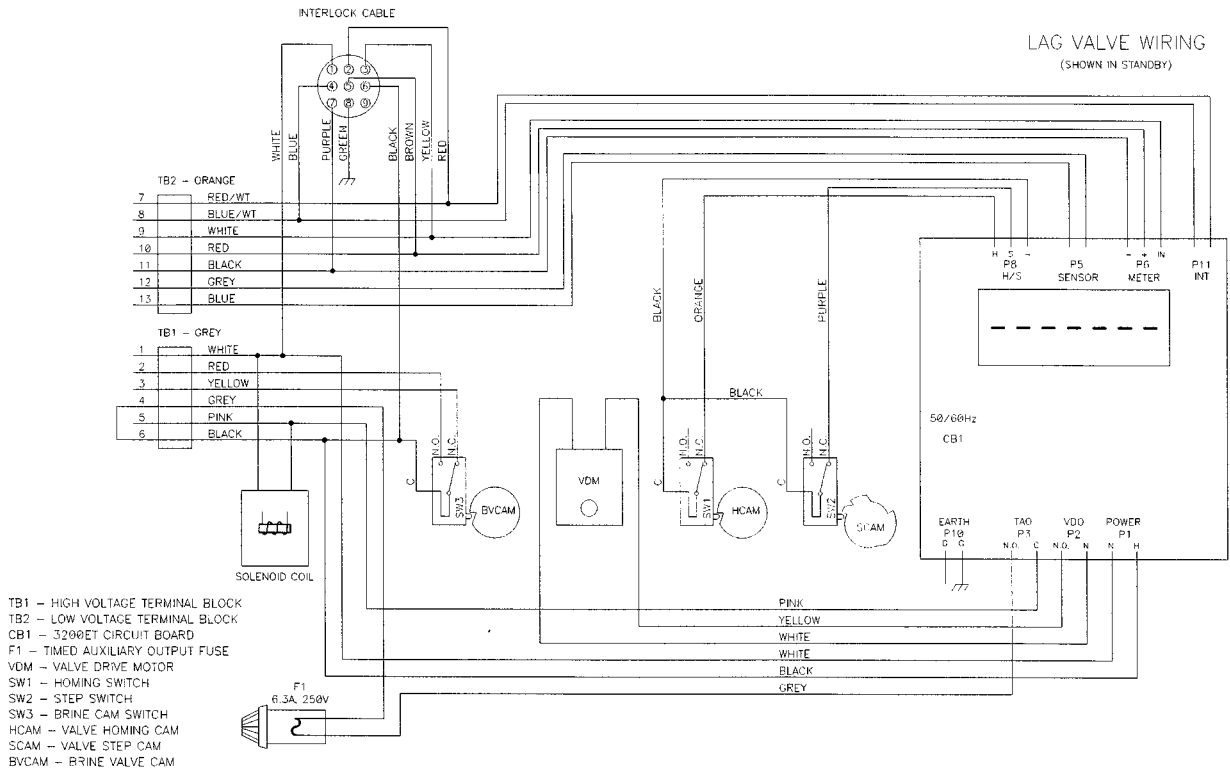

3200 Timer

3200ET Systems #7/#8 (4-Way Solenoid Output) - 2750/2850/3130/3150

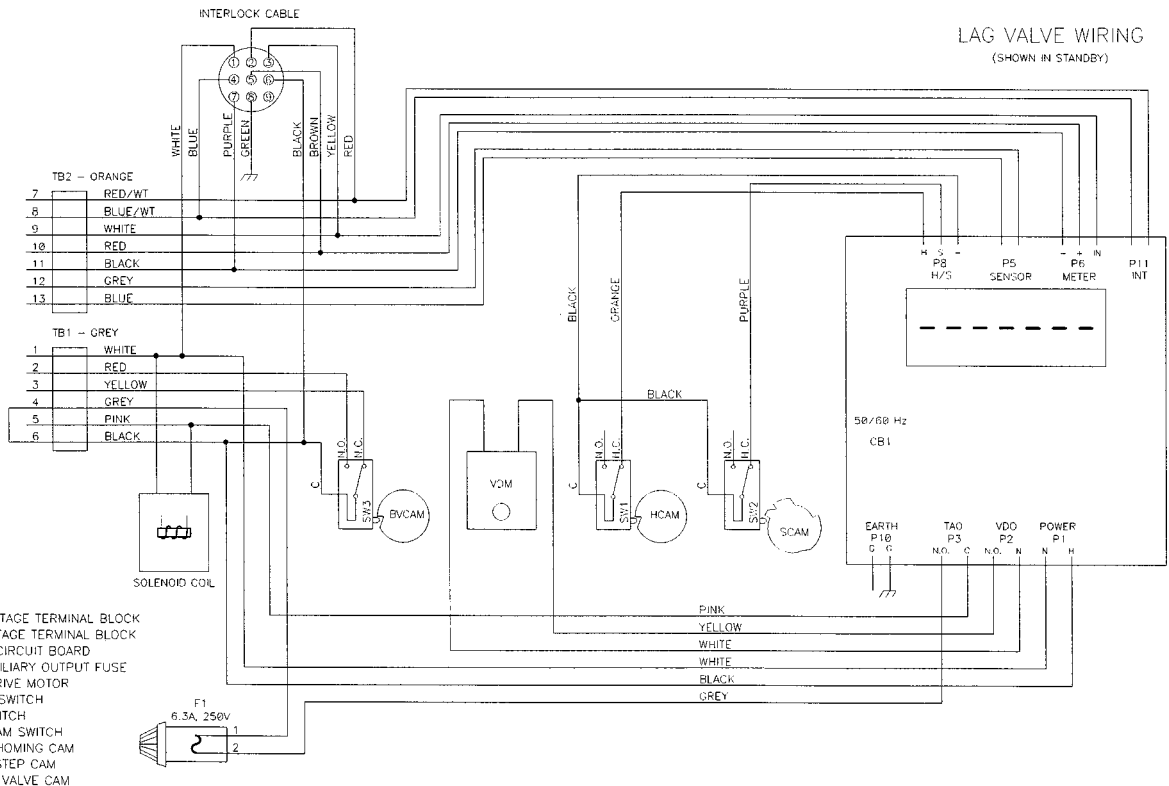
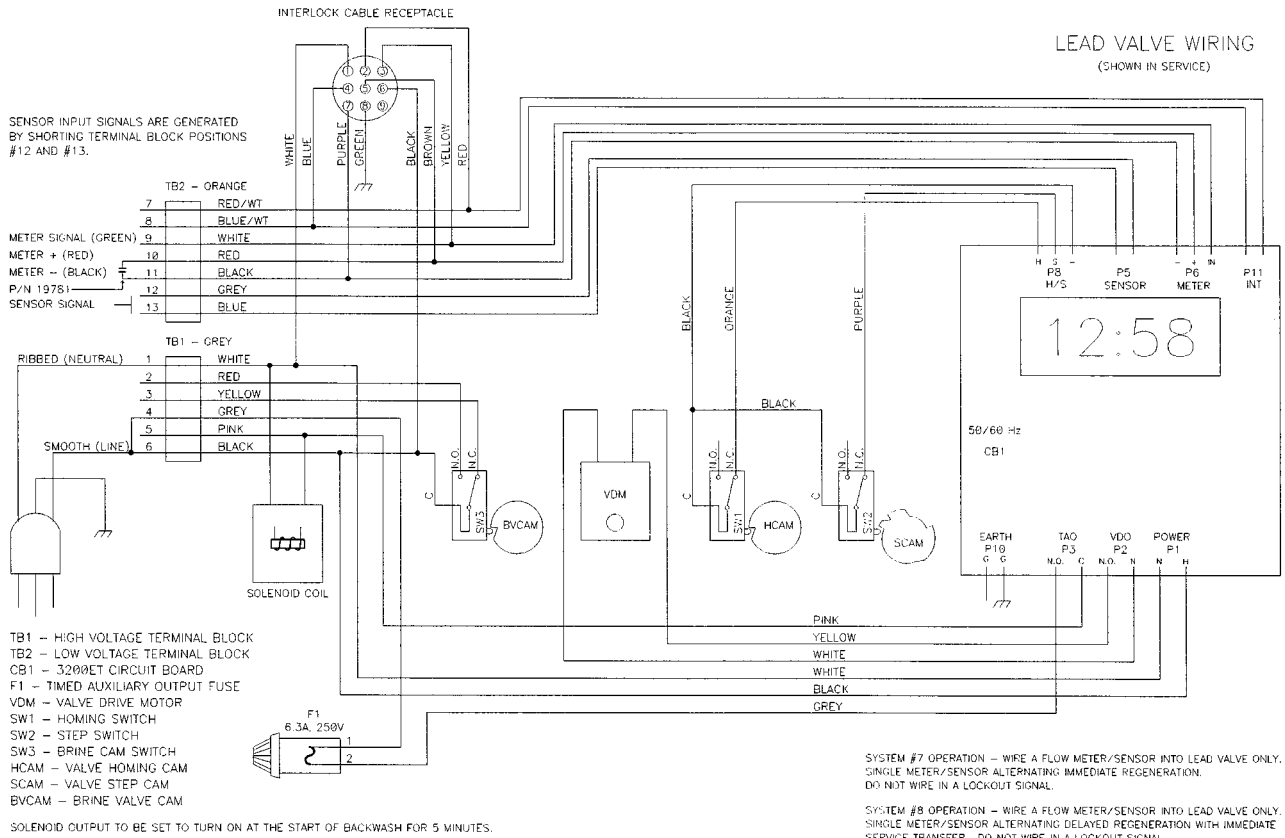

3200 Timer

3200ET Systems #7 And #8 - 2900/2930/3900

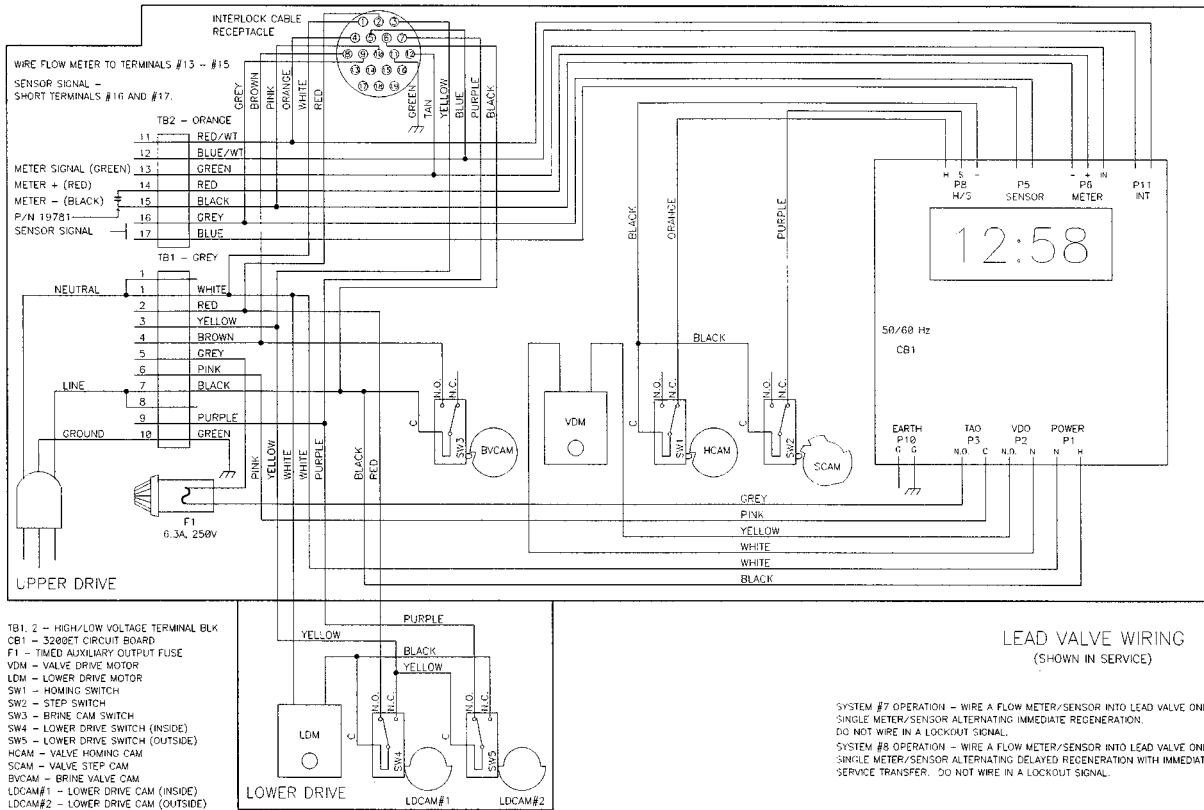

SYSTEM #7 OPERATION - WIRE A FLOW METER/SENSOR INTO LEAD VALVE ONLY. SINGLE METER/SENSOR ALTERNATING IMMEDIATE REGENERATION. DO NOT WIRE IN A LOCKOUT SIGNAL.

SYSTEM #8 OPERATION - WIRE A FLOW METER/SENSOR INTO LEAD VALVE ONLY. SINGLE METER/SENSOR ALTERNATING DELAYED REGENERATION WITH IMMEDIATE SERVICE TRANSFER. DO NOT WIRE IN A LOCKOUT SIGNAL.

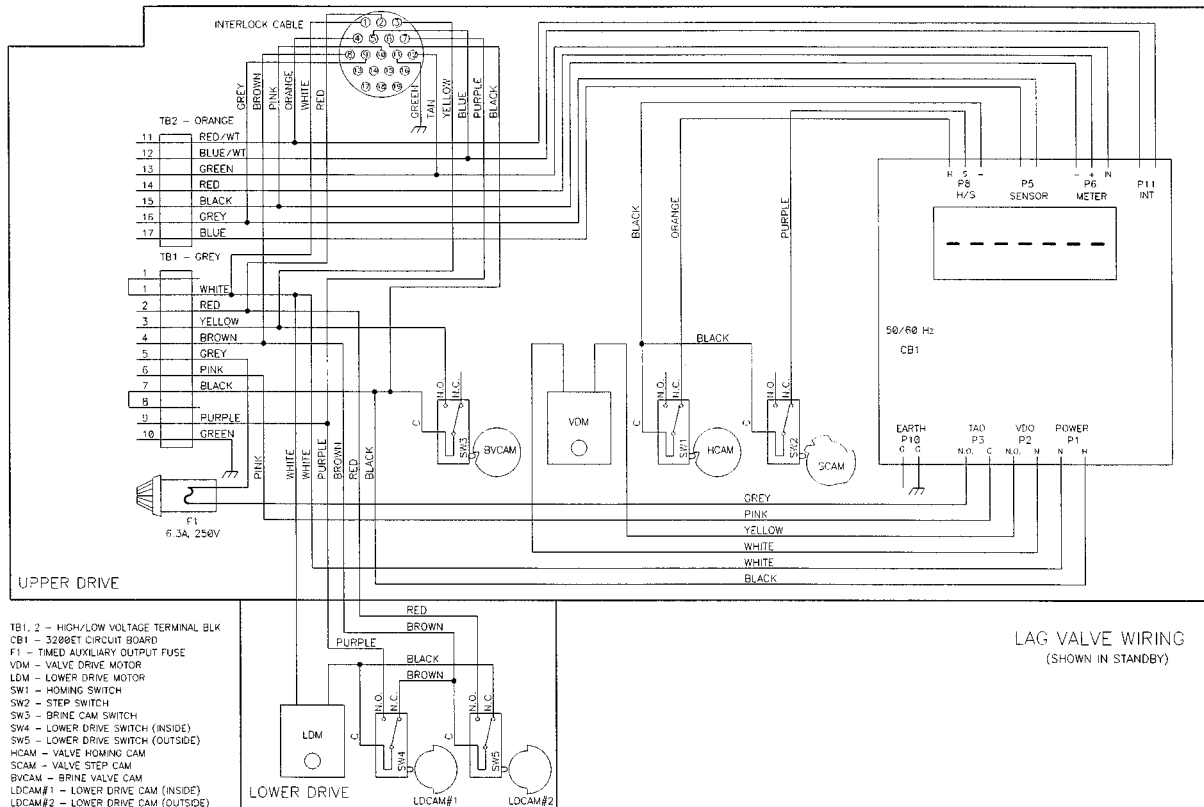

3200ET Timer

3200ET System #9 (3-Way Solenoid Output) - 2750/2850/3130/3150

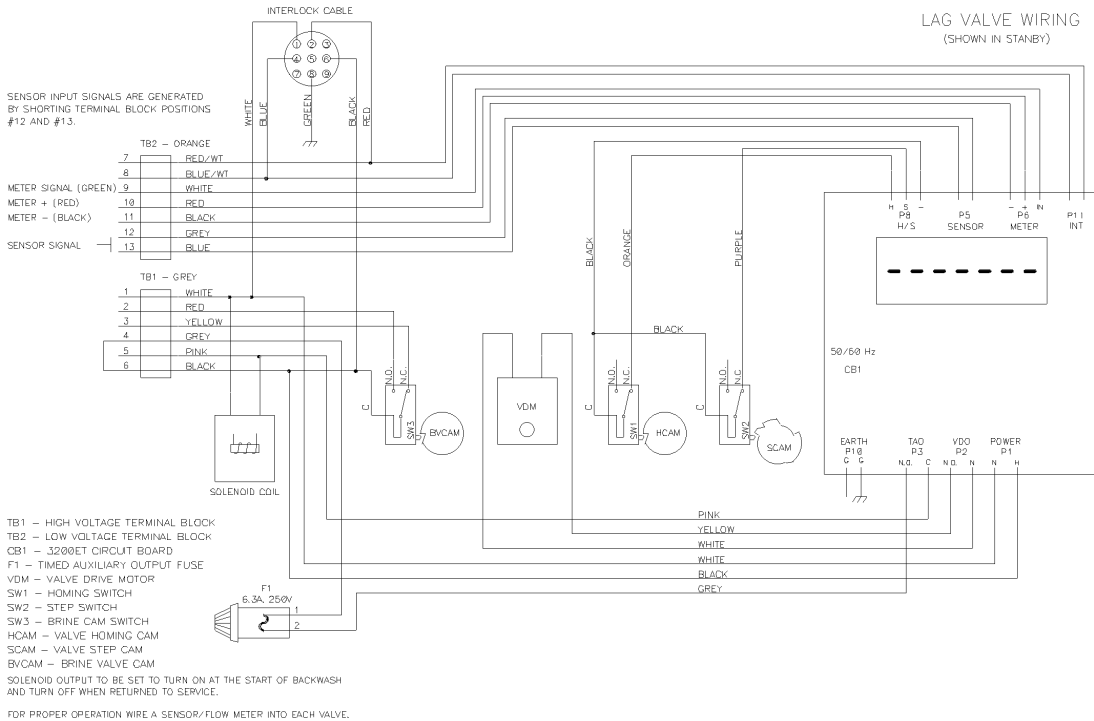
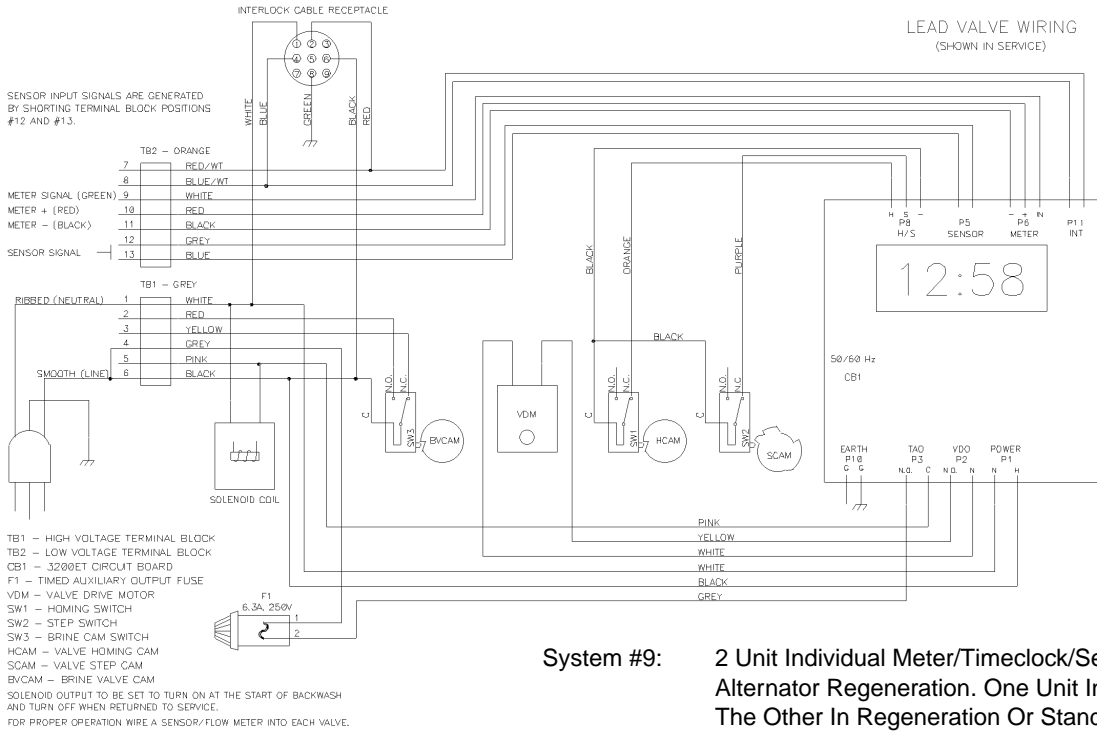

3200ET Timer

3200ET System #9 (4-Way Solenoid Output) - 2750/2850/3130/3150

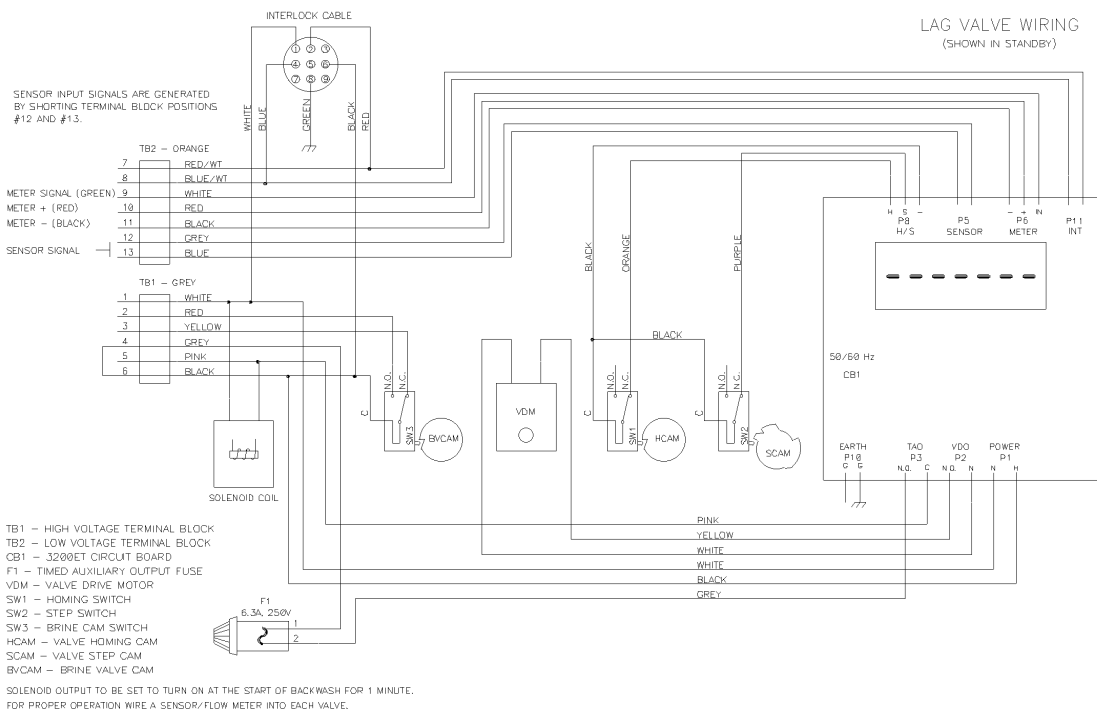
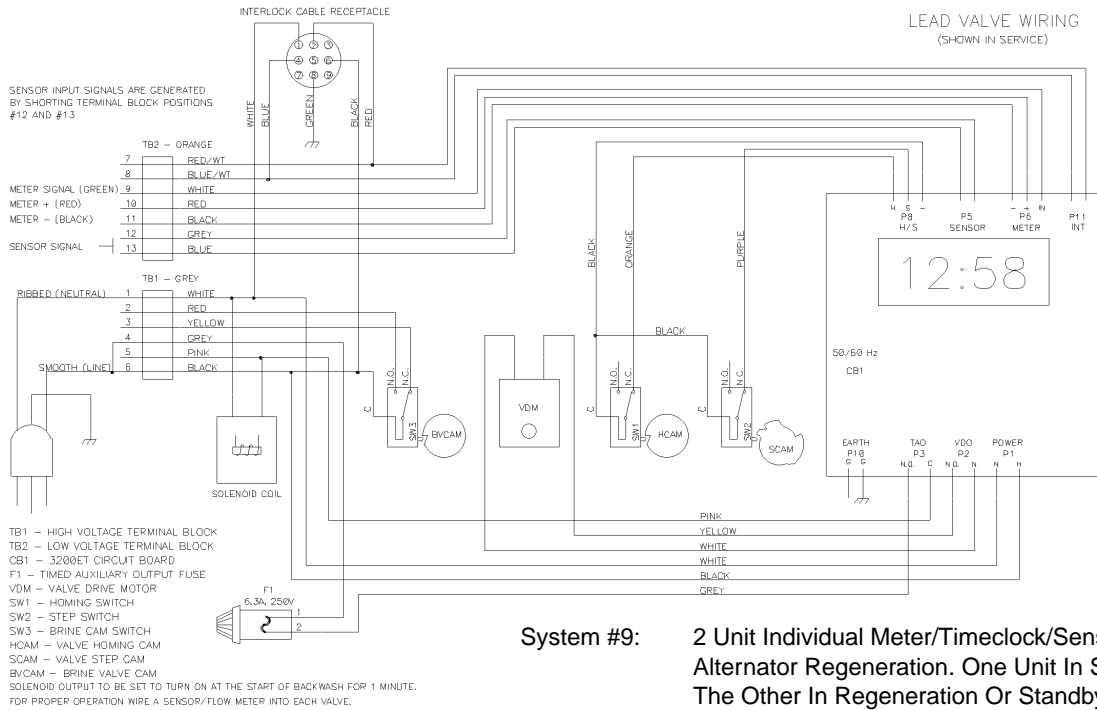

3200ET Timer

3200ET System #9 - 2900/2930/3900

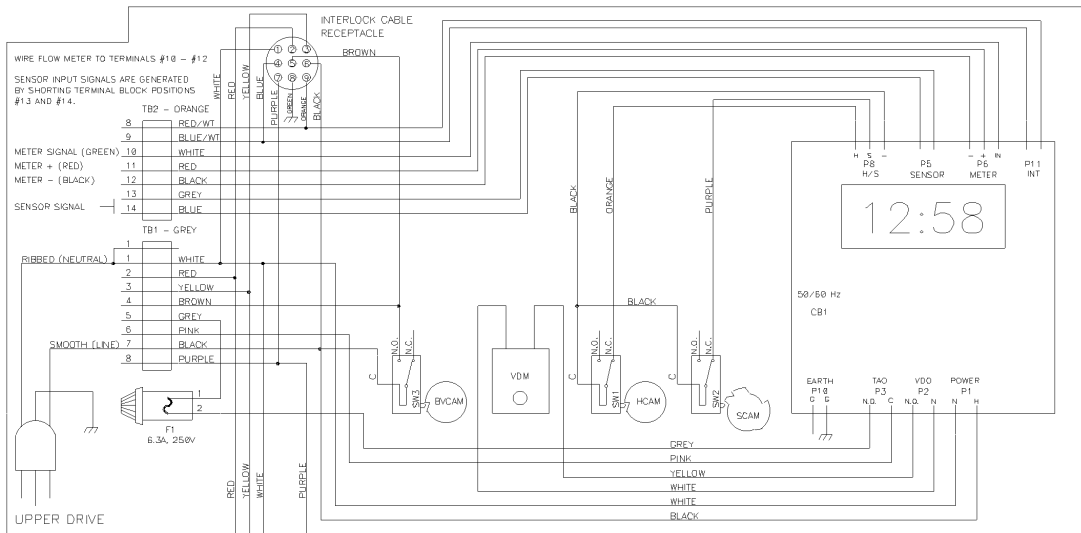

- TB1 - TERMINAL BLOCK
- CB1 - 3200ET CIRCUIT BOARD
- F1 - TIMED AUXILIARY OUTPUT FUSE
- VDM - VALVE DRIVE MOTOR
- LDM - LOWER DRIVE MOTOR
- SW1 - HOMING SWITCH
- SW2 - STEP SWITCH
- SW3 - BRINE CAM SWITCH
- SW4 - LOWER DRIVE SWITCH (INSIDE)
- SW5 - LOWER DRIVE SWITCH (OUTSIDE)
- HCAM - VALVE HOMING CAM
- SCAM - VALVE STEP CAM
- BVCAM - BRINE VALVE CAM
- LDCAM#1 - LOWER DRIVE CAM (INSIDE)
- LDCAM#2 - LOWER DRIVE CAM (OUTSIDE)

SYSTEM #9 OPERATION - WIRE A FLOW METER/SENSOR INTO EACH VALVE.
 DO NOT WIRE IN A LOCKOUT SIGNAL.

INDIVIDUAL METER/SENSOR ALTERNATING REGENERATION

LEAD VALVE WIRING
 (SHOWN IN SERVICE)

System #9: 2 Unit Individual Meter/Timeclock/Sensor Alternator Regeneration. One Unit In Service, The Other In Regeneration Or Standby

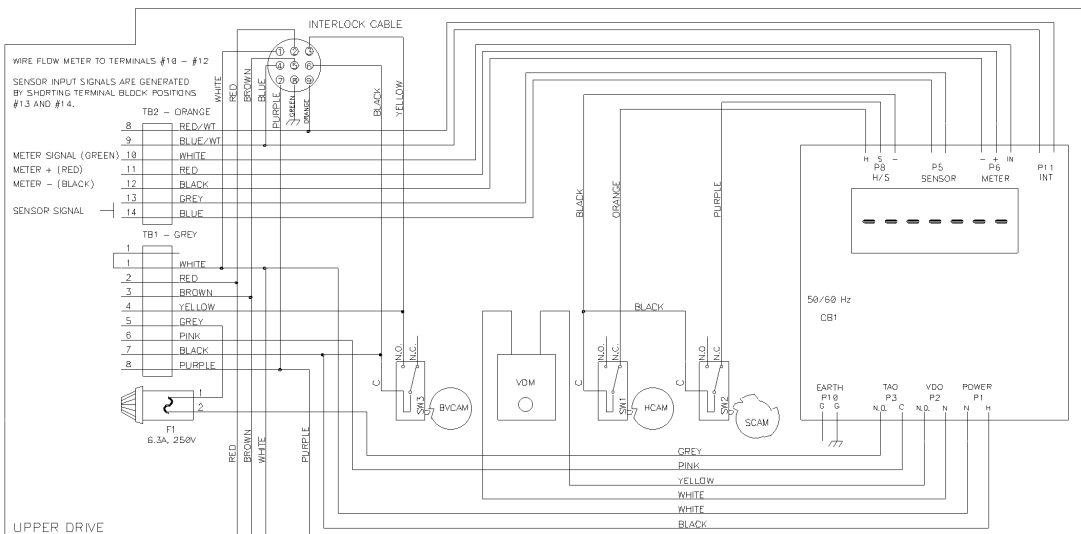

- TB1 - TERMINAL BLOCK
- CB1 - 3200ET CIRCUIT BOARD
- F1 - TIMED AUXILIARY OUTPUT FUSE
- VDM - VALVE DRIVE MOTOR
- LDM - LOWER DRIVE MOTOR
- SW1 - HOMING SWITCH
- SW2 - STEP SWITCH
- SW3 - BRINE CAM SWITCH
- SW4 - LOWER DRIVE SWITCH (INSIDE)
- SW5 - LOWER DRIVE SWITCH (OUTSIDE)
- HCAM - VALVE HOMING CAM
- SCAM - VALVE STEP CAM
- BVCAM - BRINE VALVE CAM
- LDCAM#1 - LOWER DRIVE CAM (INSIDE)
- LDCAM#2 - LOWER DRIVE CAM (OUTSIDE)

SYSTEM #9 OPERATION - WIRE A FLOW METER/SENSOR INTO EACH VALVE.
 DO NOT WIRE IN A LOCKOUT SIGNAL.

INDIVIDUAL METER/SENSOR ALTERNATING REGENERATION

LAG VALVE WIRING
 (SHOWN IN STANDBY)

Notes
